

Digital Multifunctional RC-Soundmodule TBS Mini V2

**Important notes about changes on the NEW TBS Mini V2
!!! MUST BE READ !!!**

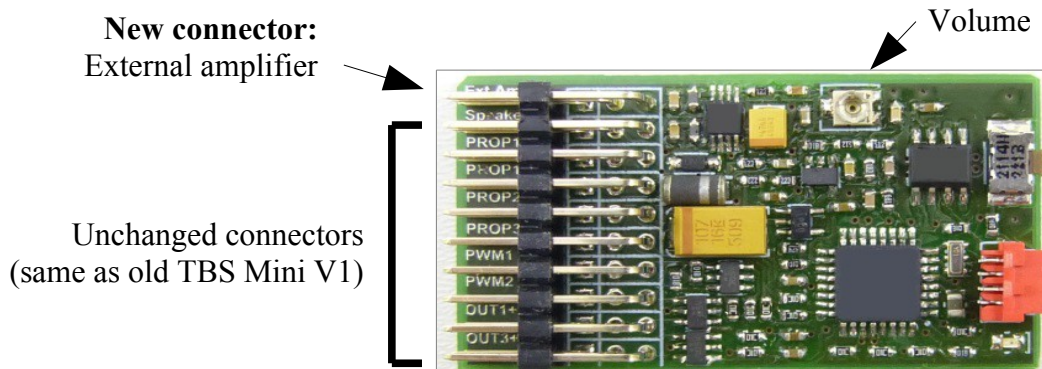

Most important: Receiver power supply must be 4V to max. 6V !!!
This range is covered by most BEC receiver power supply.

New sound memory

- 16x larger → Enough for **24,8 minutes** of sound
- „Erasing Flash“ lasts about **45s**
- Filling the new sound memory **completely** takes about **45 minutes** !

The **NEW TBS Flash V4 software** must be used for programming this TBS Mini

3W digital audio amplifier on board

40hm and 80hm speakers can be used

External amplifier connector on top → see picture above.

All other connectors remain unchanged and are located one position lower than on the old TBS Mini. Please see the TBS Mini V2 manual page 4 for all details.

The new connector allows direct usage of most 3rd party amplifiers.

Hardware volume controller located on the Mini. Internal and ext. amplifier volume is set by this controller. In parallel it is still possible changing the volume by the transmitter (if the Mini parameters settings are accordingly)

External amplifier and a speaker connected directly to the TBS Mini can be used in parallel

Very important:

Connecting any 3rd party amplifier is FULLY on your OWN RISK regarding ANY damages
There will be no support for any 3rd party amplifier.

Manual

Digital Multifunctional RC-Soundunit

TBS Mini V2

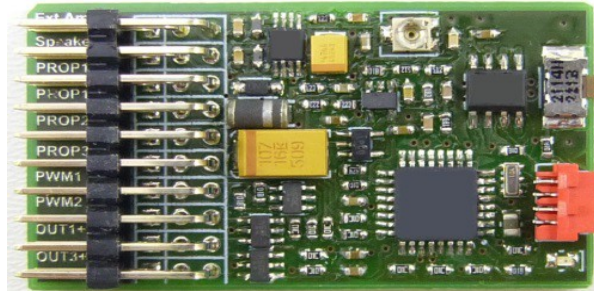

Set control mode at delivery

Encoder (PROP3)
-> **Page 5**

Direct sound selection (PROP2)
-> **Page 7**

Indirect sound selection (PROP3)
-> **Page 8**

Autostart
-> **Page 9**

OpenPanzer Configuration -> see www.openpanzer.org

Loaded sound: _____

Flashing output: None Out1 Out2 Out3 Out4

Comment: _____

TBS Flash version: Version 1 Version 4

1. Features

The TBS Mini is developed for all kind of RC controlled models, f.e. air planes, helicopters, tanks, trucks, cars, ships, A large collection of original sound records is available.

New features of the TBS Mini V2:

- Onboard 3W digital audio amplifier for 4 and 8 Ohm speakers
- Volume control on board
- Easy connection of external amplifier modules
- Watch the **limited supply voltage range of max. 6V** (= receiver supply voltage)

- Fully customer programmable. Your own sounds can be loaded!
- Large sound library of original recordings available. Please check www.benedini.de
- Sound quality 22KHz, 8Bit, Mono
- Capability to play two sounds simultaneously (engine and one special sound)
- 16Mbit sound memory, enough for 93sec. at 22KHz
- Internal amplifier with 3W at 4 Ohm speaker
- External high power amplifiers available to meet different model requirements.
- **Remote** (depending on control mode) or local volume control
- Up to 6 switching outputs
 - Can be triggered by a sound (f.e. Muzzle flashing) or independently (universal switching)
 - Switching-, momentary- or flashing mode possible
- Only **one** proportional channel necessary to control **all** functions of the unit.
- Speed signal derived from the receiver. This allows combination with brushless or brushed motors.
- Small and low weight
- USB programming cable available (optional)
- Totally programmable by the free of charge software "TBS Flash":
 - You can load your own sounds or any of the Benedini sounds available at www.benedini.de
 - Firmware update! This means you have always the latest software at you unit.
 - **FREE OF CHARGE sound libraries available at www.benedini.de**

The TBS Mini soundunit can be fully configured by the optional programming cable and a common PC. Please see the separate manual for the TBS Flash software.

The unit can be controlled by a spare proportional channel by one of the following modes:

- 12-position encoder (combination of rotary switch and push button)
- 3-position switch for **direct** sound selection
- 3-position switch for **indirect** sound selection
- Autostart (**NO** additional proportional spare channel necessary in this mode)

→ See detailed description of each mode in the according chapter of this manual.

2. Connection

Plugs (from top to bottom)

1. External amplifier (optional)
2. Speaker
3. Prop1 **Input** (Speed IN)
4. **Prop1 Output** (Speed OUT)
5. Prop2 Input (optional)
6. Prop3 Input (optional)
7. PWM1 (Servo 1 or Out 10)
8. PWM2 (Servo 2 or Out 11)
9. Out 1+2 switching output
10. Out 3+4 switching output

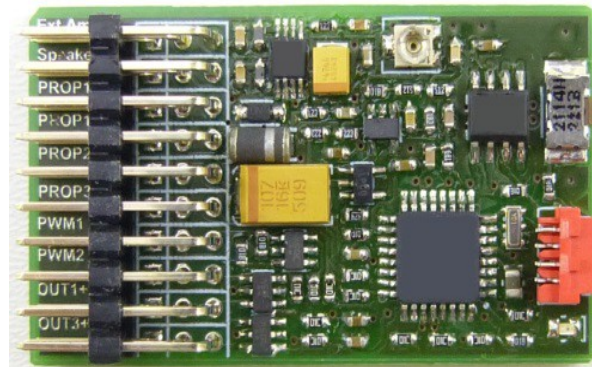

Watch plug orientation

!!! Signal lead is always on TOP (orange or white) !!!

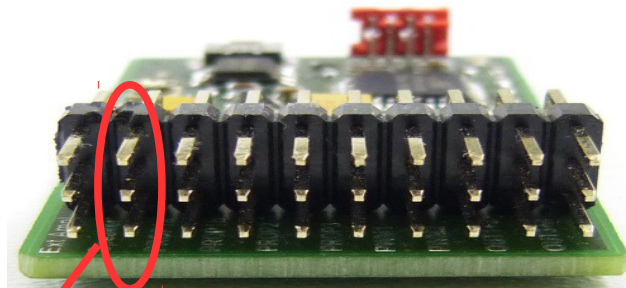

Top: Signal (orange)
Center: Power (red)
Bottom: GND (black)

Ext. Amplifier	Speaker	PROP 1 In	PROP 1 Out	PROP 2 In	PROP 3 In	PWM 1 (OUT 10)	PWM 2 (OUT 11)	OUT 1+2	OUT 3+4
NC	Speaker Plus	Signal (In)	Signal (Out)	Signal (In)	Signal (In)	Signal (Out)	Signal (Out)	OUT 2 (Minus)	OUT 4 (Minus)
Signal	Speaker. Minus	Plus	Plus	Plus	Plus	Plus	Plus	Plus	Plus
Minus	Frei	Minus	Minus	Minus	Minus	Minus	Minus	Out 1 (Minus)	OUT3 (Minus)

External amplifier:

Most commercial amplifier modules with high impedance input can be connected directly. Volume is set on the TBS Mini. If a common servo cable is used for making the audio connection, **RED** is signal and **BROWN** is ground. **DO NOT CONNECT A SPEAKER TO THIS PORT !!!**

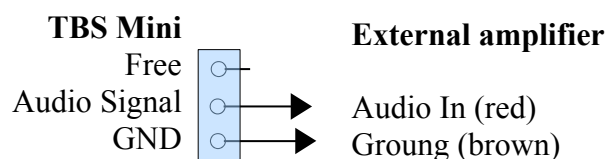

Remote volume control

If “Encoder” or “Indirect sound selection” control mode is used, the volume can be set remotely from the transmitter (If the TBS Mini parameters are set accordingly!)

Standard setting: Function Nr. 11: Volume up Nr. 12: Volume down

Operation:

Select the desired function and **KEEP** it triggered → Volume changes constantly

If the desired volume is reached, release the trigger button.

Speaker:

If the speaker is connected by a common servo cable, use the **ORANGE** (+ speaker) and **RED** (- speaker) lead. Brown is not used.

4 or 8 ohm speakers can be used. Make sure not using the amplifier connector of the TBS Mini !

Prop 1 (Receiver speed channel)

Prop1 is available twice, both are identical. The receiver speed channel is connected to one of them, the ESC can be connected to the second one.

Note:

If a **ESC with integrated BEC** is used for powering the receiver, it is highly recommended using a separate **servo y-cable** for connecting the receiver speed channel to the ESC and Prop1 of the TBS Mini. This ensures that the receiver supply current (coming from the ESC) flows directly to the receiver and not through the sound unit.

Prop2 (optional)

This multi functional receiver input can be configured to the following:

- Second speed channel input for tracked models
 - Control input for selecting the desired sound to play
 - Sensor input for load dependant sound adjustment
- Please see details on the TBS Flash manual.

Prop3

Receiver input for selecting the desired sound to play.

PWM 1

Servo1 signal or switching output (Out10)

→ Please see details on the TBS Flash manual.

PWM 2

Servo2 signal or switching output (Out11)

→ Please see details on the TBS Flash manual.

Out 1-4

Universal switching outputs

Hints to switching outputs Out 1-4, Out 10 and Out 11

The desired outputs must be configured by the TBS Flash software according to the desired functionality (switching, momentary, flashing). This can be done by the TBS Flash software and the optional USB programming cable.

!! All outputs are switching to NEGATIVE of the receiver supply voltage !!

PLUS is available at the centre contacts of each connector → See connection picture above.

Out 10 is located at the signal pin of PWM1 (upper pin)

Out 11 is located at the signal pin of PWM2 (upper pin)

2.1. Installation schematic (→ See also last page)

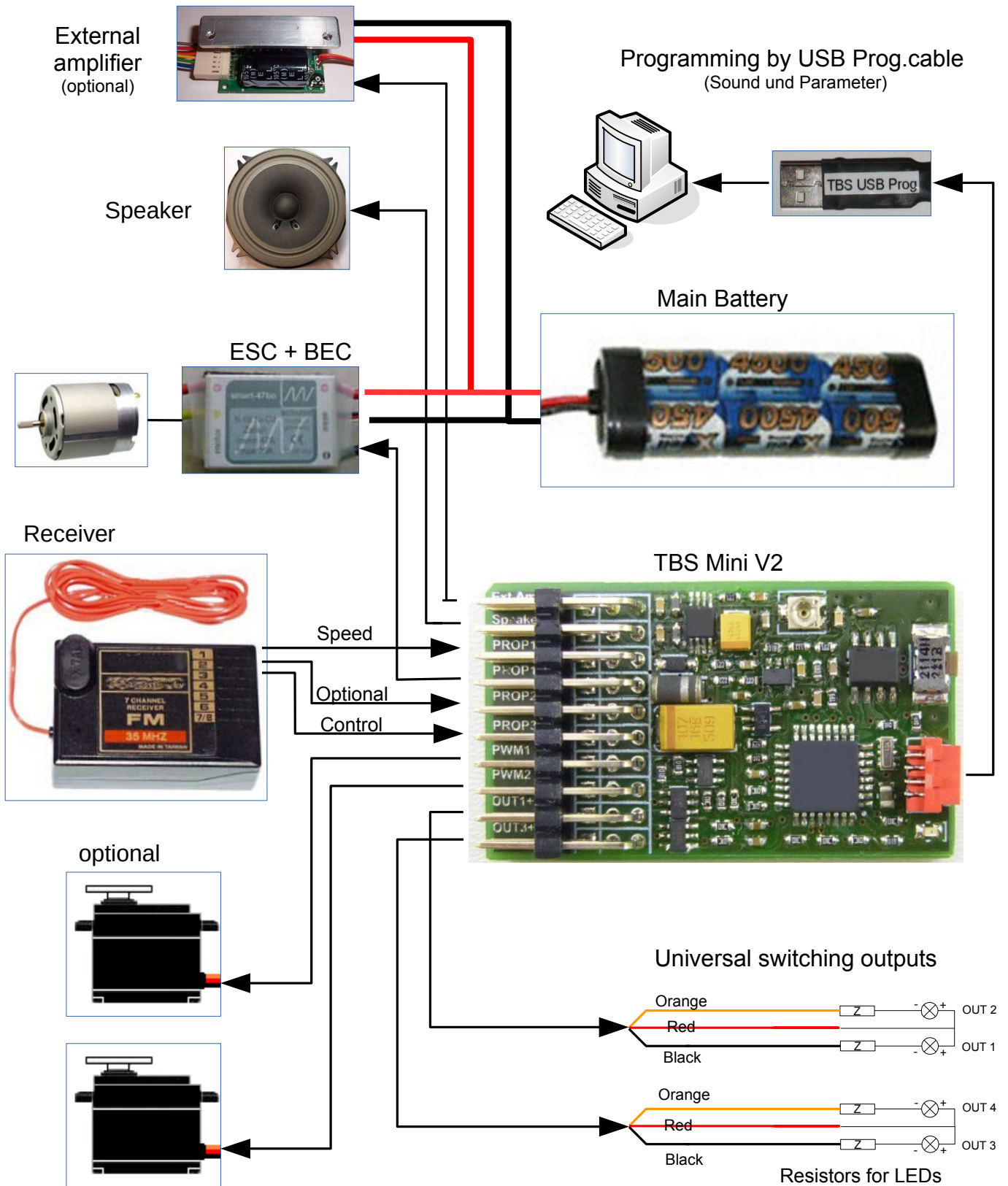

First setup

Important:

! Watch safety aspects at the end of this manual before first flight !

The TBS Mini is delivered full programmed and **ready to run**, according to your order.

!! For the final setup YOU must teach it to your radio !!

The control mode set at delivery is indicated at the first page of this manual.

Please see the following chapters how to teach the Mini according to the set control mode:

Encoder: Page: 5

Direct sound selection: Page: 7

Indirect sound selection: Page: 8

Autostart: Page: 9

!! Any configuration changes should be made AFTER the first setup was successfully !!

3. Control modes

3.1. Encoder (12-Key coder)

The most comfortable way of controlling the sound unit is using the so called “12-key coder”. It is a 12 position rotary switch in combination with a push button. The desired sound is **selected** by the rotary switch and is **triggered** by the push button.

The encoder is mounted in your transmitter and connected to a spare proportional channel.

Electrically, it is a simple potentiometer with adjustable total resistance (see picture below).

The encoder is optional and must be ordered separately!

After installation the encoder should be tested by a common servo at the according receiver channel. **KEEP** the encoder push button pressed while moving the rotary switch through all positions. The attached servo must move to a **new** location at **each** rotary switch position. The total movement of the servo should be about the same as at a normal joystick channels set to 100% travel.

Rotary switch for
sound selection

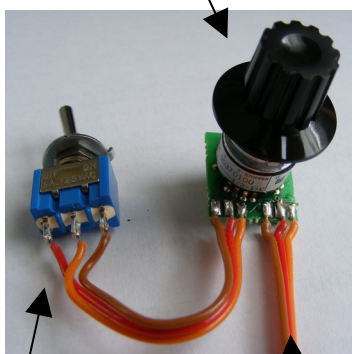

trigger switch

Connect to spare prop.
Channel of your TX.

The total resistance of the encoder can be adjusted to your TX by two solder bridges at the rear side of the encoder pcb:

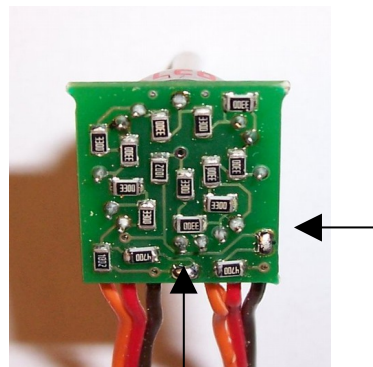

BOTH bridges

open
closed

Total resistance

app. 22 KOhm
app. 5 KOhm

3.1.1. Push button encoder

A simple resistor array combined with some push buttons can be also used to control the sound unit in 12-key coder mode. This is only a suggestion and needs to be build by your own:

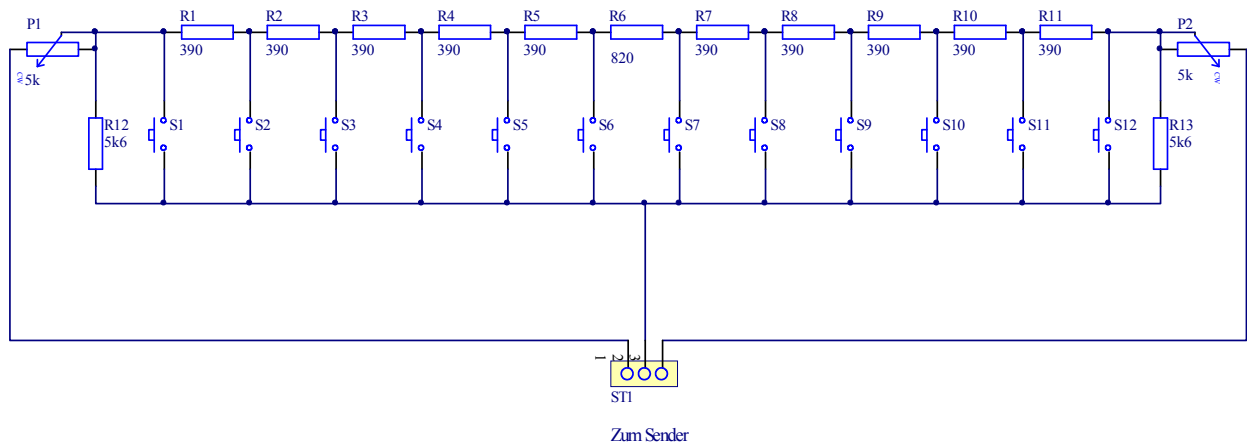

You should check the operation by a common servo. Adjust the min. and max. travel range with the potentiometers P1 and P2 in comparison to the travel at a common joystick channel(f.e.Ch1).

The installation of ANY encoder in your transmitter is on your own risk
Proper functionality is not guaranteed in ALL transmitter brands / types
After installation the proper operation and range of the radio MUST be checked

3.1.2. Teaching the sound unit for encoder control

- 1) Power transmitter and receiver. LED blinks fast -> normal mode
Bring all joysticks to neutral position. Model must not move.
- 2) Press the LEARN button at the TBS Mini until one beep plays -> LED cont. lit.
At this moment all neutral / idle positions are stored.
- 3) Move throttle stick to your desired acceleration point (throttle stick position where idle sound is left and acceleration sound is started) and push the **encoder trigger button !** -> A short sequence of acceleration is played
- 4) Move throttle stick to full speed and push the encoder trigger button again
→ A short sequence of full speed is played.
- 5) Bring the encoder rotary switch to its first position and push the encoder button
→ Engine start/stop is stored to this position
Hint: The rotary switch has no mechanical limits. You can define any position as the “first” one.
- 6) Bring the encoder rotary switch to the next position, wait about 2s and push the encoder button again.
-> Reving up the engine is stored to this position
- 7) Repeat step 6 until all 12 rotary switch positions are stored
- 8) After teaching all positions the sound unit beeps 3x and is back in normal operation mode.

Hint:

If you are using the resistor network shown above instead of the encoder, each rotary switch position is represented by one of the push buttons.

3.2. Direct sound selection

If you want to have engine sound and **ONE** special sound (f.e. MG), you can use this control mode. A proportional spare channel having a 3 position switch or a common joystick channel are necessary for using this mode.

A attached servo must leave its center/neutral position if the switch is pressed in one direction and must return to its center position when the switch is released. Pushing the switch in the opposite direction causes the servo moving to the other side. Please compare the very left and very right positions of the servo with a common joystick channel. They should be about the same.

This is the first test you should do before teaching the sound unit.

3.2.1. Teaching direct sound selection using Prop2 input (recommended !!!)

The 3pos switch receiver channel must be connected to **Prop2** input of the TBS Mini. Prop2 input mode must be set to “**Function ½**” at the TBS Flash software. The desired sounds must be selected too. **These settings are already done if this control mode was ordered.**

Teaching is very simple and is the same as described below in “**3.4. Autostart**” → **Page 10**

Hint:

The two selectable sounds are fix (as set by the TBS Flash program) and can not be changed during teaching. They can be changed only by the optional USB programming cable.

3.2.2. Teaching the direct sound selection using Prop3 input (Recommended for experienced users)

This is a **alternative** method for direct sound selection. It can be used if the model has two speed channels. In this case Prop2 can be used for the second speed input and Prop3 for sound selection.

1. Power on transmitter and receiver. LED blinks fast -> normal mode
Bring all joysticks to neutral position. Model must not move.
2. Press the prog. button until one beep occurs -> LED cont. on.
At this moment all neutral / idle positions are stored.
3. Move throttle stick to your desired **acceleration** point (throttle stick position where to leave idle and start the acceleration sound), flick the toggle switch and set it **back** to center.
-> A short sequence of acceleration is played
4. Move throttle stick to full speed position, flick the switch again and set it back to center.
-> A short sequence of full speed is played.
5. Flick the switch **UP** and set it back to center
-> Engine start/stop is stored to this switching direction
6. If you want to **skip** the next sound, flick the switch again **UP**. A section of the next sound is played but **NOT** stored to this direction of the switch, because it is already occupied.
7. Repeat step 6 to **skip** further sounds
8. If your desired special sound comes up **next** flick the switch **DOWN** and set it back to center.
9. Switch sound unit **off** and **on**.
10. Now you can select the two selected sounds directly by operating the switch up or down.

Hint:

- The control mode for Prop3 must be set to “**12 position encoder**”
- The 3-pos switch receiver channel must be connected to **Prop3**
- You may run the teaching sequence several times because you don't know at the very first run which sound appears next in the sound list.
- Advantage of this way of using the **direct** mode is, that you can choose the sounds you want to have during teaching.

3.3. Indirect sound selection “2-Key Coder” on Prop3

This control mode allows playing **ALL** loaded sounds of the TBS Mini.

A spare proportional channel of your radio having a 3 position switch with neutral position or a common joystick channel can be used.

A attached servo must leave its center/neutral position when the switch is pressed in one direction and must return to its center position when the switch is released. Pushing the switch in the opposite direction causes the servo moving to the other side.

Please compare the very left and right positions of the servo with a common joystick channel. They should be about the same.

This is the first test you should do before teaching the sound unit.

Operation of this mode:

The desired sound (f.e. sound #3) is **SELECTED** by pushing the switch/joystick 3 times from its center position to one direction, but it is **NOT** played. The already selected sound is **TRIGGERED** by pushing the switch to the **other** direction. The last selection can be triggered multiple times.

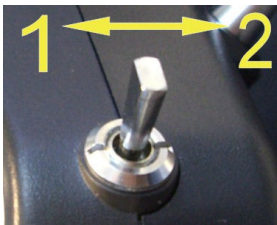

- 1: Selection** of sound / action (1-12)
- 2: Triggering** of selected sound / action

3.3.1. Teaching the “2-Key Coder” control

1. Power on transmitter and receiver. LED blinks fast -> normal mode.
Bring throttle stick(s) to neutral and the 3-position control switch to its center position
2. Press the programming button -> Beep and LED permanent on.
At this moment all neutral positions are stored.
3. Move throttle stick to your desired acceleration point and keep this position.
(throttle stick position where the engine sound leaves idle)
4. Flick the 3-position control switch at the transmitter and set it back to center
-> A short sequence of acceleration is played.
5. Move the throttle stick to full speed and keep this position
6. Flick the 3-position control switch at the transmitter and set it back to center
-> A short sequence of full speed is played.
7. Sound unit returns to normal operation mode → Green LED is blinking fast

3.4. Autostart

If you want to have **ONLY** engine sound, “Autostart” mode can be used. The engine starts automatically at first short acceleration.

If the engine runs more than 20s idle, it shuts down automatically.

There is no extra spare channel of your radio necessary.

Hint: NO special sounds and NO switching outputs are possible !!!!

Teaching the autostart mode:

1. Power on transmitter and receiver. LED blinks fast -> normal mode
Bring throttle stick to idle. Motor must not move.
2. Press the programming button until beep -> LED cont. on.
At this moment the idle position of the throttle stick is stored.
3. Move throttle stick to your desired acceleration point and wait for a beep
(throttle stick position where idle sound is left and acceleration sound is started)
4. Move the throttle stick to full speed position and wait for three beeps.
5. Sound unit returns to normal operation mode → Green LED is blinking fast

Hint:

After you left the last stored throttle stick position, a very short beep is played. Since then, you have about 2 seconds to adjust the new throttle stick position to be stored next.

4. Changing a already set control mode

The control mode can be changed also manually by the learn button of the TBS Mini **without** the optional programming cable and the TBS Flash software.

1. **KEEP** the learn button of the TBS Mini pressed while powering the receiver.
2. Release the button
3. Press the learn button momentarily and wait for the “Beep-Code”
4. Repeat pressing the button until the desired control mode is signalized by the according “Beep-Code”
5. Switch sound module off and on again

„Beep-Code“

1 x Beep	->	Autostart
2 x Beep	->	Indirect sound selection (2-Key coder)
3 x Beep	->	12- Key coder

Note:

This will NOT work for changes **from Autostart** to 2-key or 12-key coder mode, due to a missing sound list definition.

Changes vice versa are possible.

6. Configuration of the soundunit by the optional programming cable and a common PC

Please see the separate manual for the configuration software called "TBS Flash".
The manual as well as the software is available free of charge at www.benedini.de.

Note:

The sound unit must be powered from the receiver or a receiver battery while being connected to the PC. It is **NOT** powered by the USB cable!

7. Technical datas

Power supply: 3,5V – **max. 6V** (powered from the receiver)
Internal amplifier: 3W at 4 Ohm and 5V supply
Switching outputs: Negative switching, max. 12V/0,5A each
Dimensions: 55 x 28 x 10mm
Weight: about 6g

!!!! SAFETY ASPECTS !!!!

- You must do a **range check** of your remote control with **running** sound system !
- Ensure a proper working radio under **ALL** conditions !
- **Receiver Power supply:**

If a **speed controller BEC** is used for powering the receiver, it is highly recommended using a separate servo **Y-cable** for connecting the **receiver** to the **ESC** and the **TBS Mini** (speed channel). In this case the receiver is powered **directly** and not via the two Prop1 connectors of the TBS Mini. Maximum current of the Prop1 connectors are **2A**, if according wires are used!

- The switching outputs of the TBS Mini **MUST** not be used to trigger any dangerous actions in the model (f.e. triggering any firing mechanisms)

Disclaimer

- www.benedini.de provides the equipment solely to be used by each purchaser in accordance with the specific instructions supplied with each Sound Module and that the purchaser undertakes that the Sound Module and any associated equipment e.g. Amplifier, Speakers, etc. will be operated within the parameters contained therein.
- www.benedini.de accepts no liability for any damage to any Sound Module if it is determined that the damage has been caused by either non adherence to the instructions or due to any malfunction by any cause or reason whatsoever within the model or its equipment and thereby outside of the control of www.benedini.de.
- www.benedini.de supplies each Sound Module on the strict undertaking that it will be used in such a manner to comply with the laws of the purchaser's country of residence.
- www.benedini.de has no control over the final assembly, no liability shall be assumed nor accepted for any damage resulting from any use by user of the final assembled product, the user accepts all resulting liability.

Technical changes reserved

Not suitable for children under 14 years



Benedini Modellbauelektronik
Müllergasse 15, 52159 Roetgen, Germany
Web: www.benedini.de
Mail: Thomas@Benedini.de



Attention: !!! Picture shows the “old” TBS Mini !!!

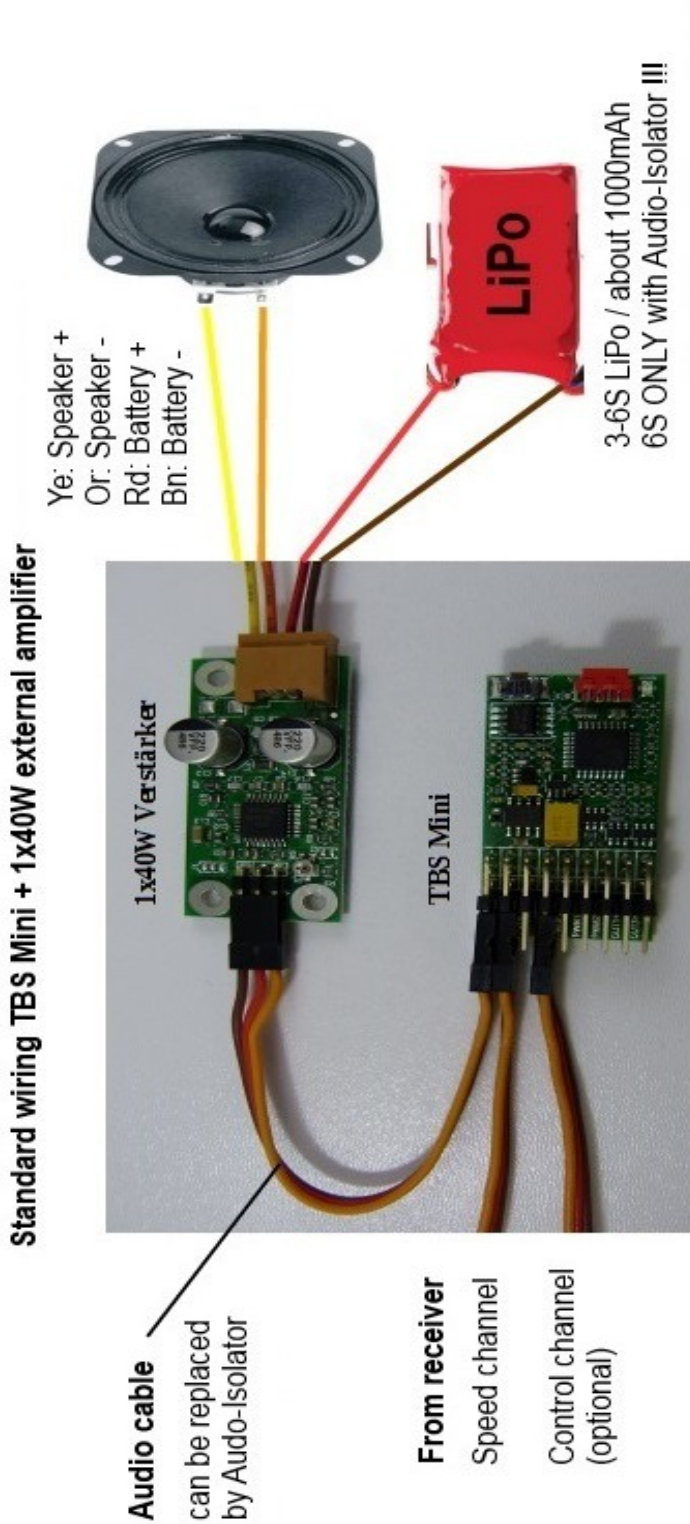

Connecting two speakers to the 1x40W amplifier

-> Amplifier manual states the wiring version to use

